



VERTERE™



At the heart of Music

# THE RECORD PLAYER

RG-1 | SG-1 | MG-1 Vertere Record Player systems

Reference Tonearm New Gen. Absolute Reference Tonearm

SG-1 Super Groove TPA Tonearm MkII Super Performance Tonearm  
Pulse Hand-built Internal Wiring

SG-1 Super Groove TPA Tonearm MkII High Performance Tonearm  
Standard Pulse Internal Wiring

RG-1 Reference Groove Reference Record Player

SG-1 Super Groove Super Performance Record Player

MG-1 MkII Magic Groove High Performance Record Player

RG-1 Reference Motor Drive Absolute Reference

SG-1 Super Groove Motor Drive MkIII Super Performance

Mystic Moving Coil Cartridge Super Performance

Magneto Moving Magnet Cartridge Performance

# THE RECORD PLAYER

Vertere Reference Tonearm

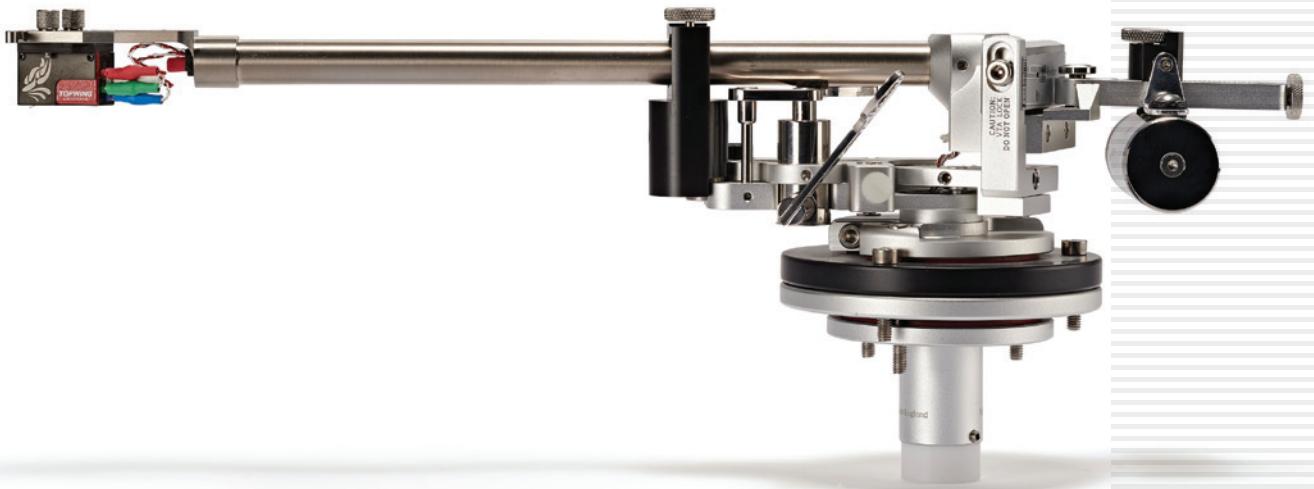

## Vertere Reference Tonearm | New Generation

Since its debut in 2014, Vertere's Reference Tonearm has been the absolute benchmark. The resolution achieved from almost any high-quality phono cartridge supported by the Reference Tonearm has been unsurpassed and unrivalled.

In a crucial development, this state-of-the-art design overcame the limitations of all conventional tonearm bearing systems. Uniquely, the tonearm's vertical and horizontal pivoting motion is provided by non-rotating flexible elements. Because there are no sliding surfaces, the change-of-direction friction of conventional bearings is eliminated, to create the first truly 'noiseless' tonearm bearing.

However, every other part of the tonearm was given equal attention, in a design where each detail contributed to the excellence of the whole.

By providing us with the most accurate, revealing and true-to-the-original monitoring system, this iconic tonearm has facilitated the design of all subsequent Vertere Reference products - including the acclaimed Pulse-HB cables, the RG-1 Record Player and the new RG-1 Motor Drive.

Now, after four years and substantial improvements of many 'weak links', it's been possible to revisit the Reference Tonearm itself and to identify its 'tweakable' areas. The result is the New Generation Reference Tonearm, which surpasses its predecessor on three fronts.

First, there are a number of performance-enhancing upgrades. Secondly, we've improved the ease of alignment, setup and tuning procedures. And finally, there is new packaging with a very safe in-transit clamping system.



Performance enhancements include improved routing of the internal wiring, with extra fitting and alignment procedures during manufacture to ensure the most perfectly unimpeded free movement of the tonearm. As a finishing touch, the Acetal tonearm cable connector has been upgraded to a machined piece of solid extruded P.T.F.E., the optimum dielectric.

While the Tonearm Mount Base forms the critical interface between tonearm and armboard, it also facilitates set-up and alignment. Previously, this needed to be carried out by expert personnel to achieve optimum performance, but the re-designed New Generation Tonearm Mount Base makes the procedures much easier, while also ensuring consistent performance after every cartridge remount or transportation.

The New Generation Tonearm Mount Base also enhances performance even further, as it presents an entirely coherent mechanical impedance at the tonearm/armboard interface.

One of the special features of the Reference Tonearm is its fully articulated counterweight assembly, in which the tracking weight is marginally but continuously adjusted while the tonearm moves up and down. This allows the proper tracking of the groove even on warped records. No platter clamping, outer ring or vacuum suction system can make the record flat, so correct tonearm design is the only way to help the cartridge do its job!

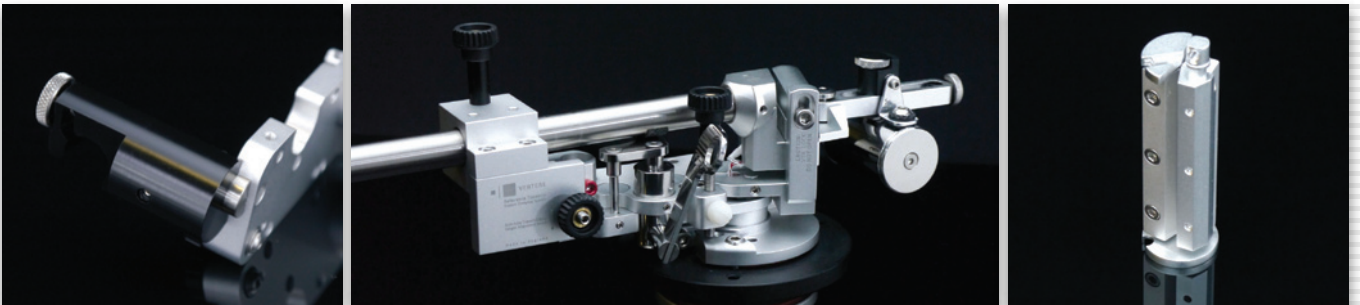

For the New Generation Reference Tonearm, we revisited the fully-articulated counterweight system and made it even better. The Counterweight Assembly now allows superfine adjustment of the tracking weight, with a locking mechanism to guarantee accurate and repeatable setups.

High-performance MC cartridges typically perform at their best when their coil assembly is symmetrical within the magnetic gap, and that is where the New Generation Reference Tonearm Counterweight Assembly comes into its own.

Our last task was to design an effective clamping system for safe transportation, even with the cartridge mounted, which would also assist in handling the tonearm safely when remounting or setting up. And this really was a challenge!

However, the final design solution also provides the New Generation Reference Tonearm with an adjustable arm clip, which makes everyday use even more of a pleasure than before. A new precision-machined stainless steel pillar rigidly fitted to the lift/lower plate acts both as the transit clamping system mount and the support for the adjustable arm clip.

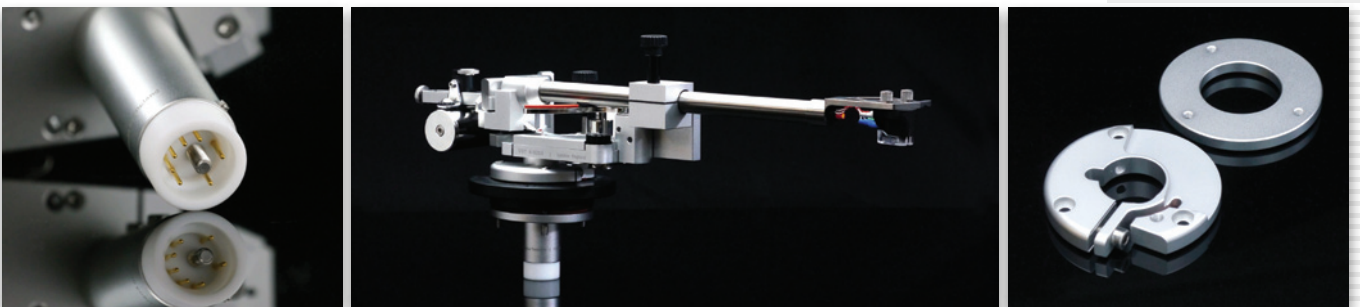

## Making Light

While the stainless-steel lift/lower mechanism itself is precision engineered for smooth, firm and accurate cueing, Vertere's unique tonearm cueing light discreetly illuminates the record grooves in the area around the stylus, making it easy to cue precisely without disturbing the mood lighting of your listening room.

Also incorporated in the New Generation Reference Tonearm are other new features - such as the new Bearing Yoke Support Modification - that help factory alignments and so achieve even better results in the field.

With the New Generation Reference Tonearm, what was once unimaginable - the thought of improving such a remarkable product - is now a reality, giving us immense satisfaction in pushing back the barriers once again.

*It brings the closest performance to the original master. Every time.*



## Specifications

Type	Pivoted	Tonearm Cable	Special Pulse-HB
Effective length	240mm Horizontal		x3 Thickness Gold Plated Contacts
	263mm Vertical		D-Fi LED Power Cable
Overhang	17.5mm	Transit Clamping System	Fully Protecting
Offset Angle	22.9°		Aluminium Alloy Armtube/Bearing Clamp
Head-shell	Titanium		Adjustable Clamp Support Block
Arm Tube	Titanium	Arm Clamp	Compression Clamp
Bearing Yoke Structure	Aluminium Alloy		Aluminium Alloy/Silicon Rubber Gasket
Bearing Type	Non-rotating Kevlar	Cartridge Alignment	Protractor & Block
Counter Weight	Stainless/Tungsten Carbide		Laser Engraved Acrylic Protractor & Acrylic VTA & Azimuth Block
	Articulated x3 Ball Races	Queuing Light Power Supply	Battery Powered
Internal Wiring	Special Hand-built Pulse	Standard Counterweight (x1)	142 g
	Signal & LED Power Wiring	Standard C/W Disc (x6)	Each 7.6 g
	x3 Thickness Gold Plated Contacts	Special Counterweight (x1)	83 g
Connector	Proprietary Cartridge & Cable connectors	Tungsten Carbide C/W Insert (x1)	114 g
	x3 Thickness Gold Plated Contacts	Special C/W Disc (x4)	Each 7.6g
	Vertere 7-way Tonearm Connector	Overall Weight (With Std C/W & x4 Discs)	Approx. 590 g

# THE RECORD PLAYER

RG-1 | Reference Record Player & Motor Drive

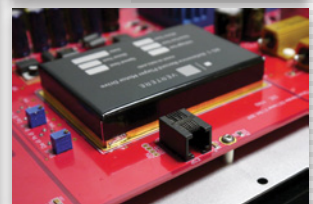

Vinyl Replay | Closest To The Original Master

## RG-1 Reference Record Player

Vertere's finest model, the Record Player RG-1 Reference Groove embodies all Vertere's unrivalled expertise in quality audio engineering, high-end hi-fi systems and turntables. Now the revolutionary RG-1 Reference Motor Drive brings the Record Player's performance to new levels of perfection.

Designed without compromise, every single component in the Record Player RG-1 is specially engineered and custom built, using the best possible materials and the highest standards of precision. A super-precision main bearing and a two-piece non-resonant platter assembly provide the most silent platform for the arm and cartridge. The result is the 'darkest' background achievable from vinyl, against which every note that's played, and every word that's sung, comes to life.

Machined and finished to the tightest of tolerances, the main bearing assembly comprises an aerospace-grade phosphor bronze housing, a super-precision tungsten carbide spindle and silicon nitride ball. The design of the bearing assembly ensures that the ball is housed absolutely central to the spindle.

On the main structure of the record player, the drive engine is a Swiss-made synchronous motor. Vertere's unique self synchronising system for the motor keeps belt tension constant and also keeps any residual noise away from the platter.

Highest-quality cast acrylic has been chosen as the best material for the plinths of the record player, due to its consistent rigidity and naturally non-resonant properties. The plinths are CNC machined from different thicknesses of cast acrylic to their specific designed shapes and are critically isolated from each other.

The intricate design of the isolation components combined with the stable acrylic plinth structure provides the best possible platform for the tonearm, cartridge and the platter assembly. The result is an unparalleled and an unforgettable musical experience, every time you play a record on the RG-1.



## RG-1 Reference Motor Drive

With advanced control circuit design implemented to its limits, the RG-1 Reference Motor Drive allows us to achieve maximum performance from the world renowned Record Player RG-1 and Reference Tonearm.

How is this? In reality, the music we hear when playing vinyl records comes from the motor! The motor is the only source of energy in the system. It is this energy that drives the record past the stylus, thus making music. This means that any noise or fluctuation in the drive system will adversely impact the music. Detail, dynamics, timbre, timing and musicality will all suffer as a result.





Synchronous motors, unlike DC motors, run at a constant speed determined by the frequency of the AC drive signal which powers them. So a well-designed Motor Drive can ensure a constant rotational speed, but for best results the alternations in the current that it sends to the motor must also have a perfectly smooth and correct sine-wave form, to eliminate the smallest fluctuations in the motor's rotation. This is not achieved by most conventional turntable power supplies

By contrast, the RG-1 Reference Motor Drive takes full control of the record player motor and provides the smoothest drive with minimum noise and distortion. The music that is extracted from the vinyl now resembles, unbelievably closely, the original master that the record was cut from.

To accomplish this, the RG-1 Reference Motor Drive utilises a microprocessor and digitally generates the exact frequencies that are required to drive the motor. After the microprocessor, a high-quality D to A Converter converts these digital signal frequencies to the necessary analogue Sine and Cosine waves, which then are amplified to the required levels by 20W audio amplifiers to drive the motor. The entire circuit and process is designed to ensure absolute motor speed stability without unwanted noise and distortion.

As well as the 'fixed' speeds of 33 and 45 rpm, fine steps in speed adjustment are provided, to correct those records where speed errors occurred during the cutting process, or existed on the original tape. The RG-1 Motor Drive's microprocessor generates the exact frequencies required, and the front-panel rotary knob offers seven fine adjustments of +/- 0.25%, 0.50%, 0.75%, 1.00%, 1.50%, 2.00% and 3.00%, relative to 33 and 45rpm.

There are also switches for 33/45 selection and Sleep/Operation modes, while fine tuning of the residual motor noise is easily carried out from the underside of the unit.

Under development for more than two years, the RG-1 Reference Motor Drive has been realised using the highest quality components throughout, to ensure the theoretical design is implemented fully and the performance optimised. No less than three dedicated toroidal transformers power the output amplifiers and the different sections of the circuitry, while three fully regulated and decoupled power supply rails power the microprocessor, the DAC and all the operating circuits.

The microprocessor is programmable via an RJ11 on-board socket and its entire circuit is fully isolated using a solid copper shield can. The entire mother board is mounted on an aluminium chassis and housed in a solid machined aluminium alloy cover.

Now at the heart of the most advanced record player in the world, the RG-1 Reference Motor Drive is truly in control - to get you closest to the original master.

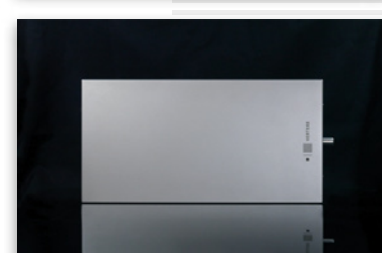
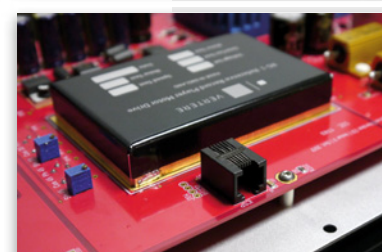



## Specifications

### RG-1 Reference Record Player

Type	Belt Drive
Motor	48 Pole Synchronous 6 Point Body Contact Support Spindle Support Acetal Ball Bearing
Motor Mount	Acetal Platform - Articulated 2 Ball Race Bearings & Silicone Motor Spring
Pulley	Super Precision Aluminium Alloy
Drive Belt	Precision Ground Polymer
Platter	Super Precision Aluminium Alloy Two Part Linear Damped 2mm Bonded Acrylic Record Interface
Bearing Spindle	Super Precision Tungsten Carbide Roundness/Concentricity & Finish < 1 Micron
Bearing Housing	Aerospace Grade Phosphor Bronze Clearance < 4 Microns
Plinth Structure	Clear or Special Printed Black Cast Acrylic 30mm Thick Top & Bottom Plinths 20mm Thick Sub-plinth & 15mm Mid-plinth
Isolation System	3 Stage Compliant & 2 Stage Rigid 12 Decoupler Sets & 12 Tuned Silicone Ring/Bobbins 3mm Acrylic Disc & Stainless Feet/Hard Rubber
Wow & Flutter	< 0.08%
Rumble	< -87dB
Dimensions	486 x 401 x 210-220mm W x D x H (mm)
Weight	23 Kg

### RG-1 Reference Motor Drive

Motor Drive	Micro Processor Controlled
Drive Circuit	Digitally Generated Signal Ultra Low Distortion/Low Noise Fully Adjustable & Programmable
Drive Signal	SINE & COSINE Waves Internal Fully Shielded DAC Amplitude/Phase Angle Adjustable
Drive Speed	Adjustable In Steps +/- (0.25, 0.5, 0.75, 1.0, 1.5, 2.0 & 3.0)%
Power Supply	Linear x3 Transformers x2 Rectifier Circuits x4 Fully Regulated DC Supply Rails
Output Drive	20W Audio Amplifiers Low Noise/Low Distortion
Drive Link	Double Pulse-HB/D-Fi 1.15m/Mini XLR
Dimensions	214 x 450 x 58mm W x D x H (mm)
Weight	4.2 Kg



# THE RECORD PLAYER

SG-1 | Super Groove Record Player & MkIII Motor Drive



## SG-1 Record Player

Bringing music to life in the home, Vertere's Record Player SG-1 Super Groove can take you close to perfection in turntable performance. In fact, the SG-1 is designed and built to exactly the same high standards as the RG-1 Reference Groove. Once again, every single component is specially engineered and custom built, using the best possible materials and the highest standards of precision.

Directly derived from the unparalleled RG-1 main bearing, the SG-1 bearing is based on the same design and geometry, with similar precision engineering techniques. The SG-1 platter is a one-piece aluminium alloy design based on the two-part RG-1 platter, while the platter/record interface is a thicker (3mm) bonded cast Acrylic disc.

As with RG-1, Vertere's lustrous Special Metallic Black, Champagne or Pearlescent White finishes are at a premium, providing a stunning and dramatic alternative to the original clear finish. Also, either model can benefit from the optional dustcover which fully encloses the Record Player while aesthetically complementing its elegant lines.



## SG-1 Motor Drive | MkIII

It is absolutely critical that the Record Player motor is powered and controlled faultlessly to ensure a full and musical performance, and in this case the SG-1 Motor Drive does just that. Designed to control the motor perfectly, and so to provide the platter with smooth and constant drive, the SG-1 MkIII Motor Drive is elegant and simple to use, with a 'supercharged' engine under its bonnet!

Unrivalled in its own right and surpassed only by Vertere's RG-1, Record Player SG-1 Super Groove plays every note with the intended emotion and maximum dynamics in any home environment. And, if desired, it also provides a trouble-free, no-compromise upgrade pathway to the RG-1 Reference.



## Specifications

### SG-1 Super Groove Record Player

Type	Belt Drive
Motor	48 Pole Synchronous 6 Point Body Contact Support Spindle Support Acetal Ball Bearing
Motor Mount	Acetal Platform - Articulated 2 Ball Race Bearings & Silicone Motor Spring
Pulley	Super Precision Aluminium Alloy
Drive Belt	Precision Ground Polymer
Platter SG-1	Super Precision Aluminium Alloy Single Piece 3mm Bonded Acrylic Record Interface
Bearing Ball SG-1	Super Precision Tungsten Carbide Roundness/Concentricity & Finish < 1 Micron
Bearing Spindle SG-1	Precision Hardened Stainless Steel Roundness/Concentricity & Finish < 2 Microns
Bearing Housing SG-1	Aerospace Grade Phosphor Bronze Clearance < 5 Microns

Plinth Structure	Clear or Special Printed Black Cast Acrylic 30mm Thick Top & Bottom Plinths 20mm Thick Sub-plinth & 15mm Mid-plinth
Isolation System	3 Stage Compliant & 2 Stage Rigid 12 Decoupler Sets & 12 Tuned Silicone Ring/Bobbins 3mm Acrylic Disc & Stainless Feet/Hard Rubber
Wow & Flutter	< 0.09%
Rumble	< -85dB
Dimensions	486 x 401 x 210-220mm W x D x H (mm)
Weight	21 Kg

### SG-1 Motor Drive MkIII

Motor Drive P/S	Precision Crystal Referenced
Speeds	33.3 & 45 rpm (< 0.25%)
Dimensions	124.5 x 225 x 55mm W x D x H (mm)
Weight	1.1 Kg

# THE RECORD PLAYER

MG-1 MkII | Magic Groove Record Player



The MG-1 MkII main bearing is directly derived from the SG-1 utilising exactly the same bearing spindle and ball with a phosphor bronze bearing housing machined using the same precision engineering techniques to our high standards. The materials used and manufacturing to extreme engineering tolerances make the MG-1 MkII main bearing silent, smooth running and second only to the SG-1.

MG-1 MkII main bearing is lubricated with Vertere proprietary formulated L-1G record player main bearing oil for ultimate longevity.

Directly derived from the RG-1 and SG-1 motor assembly design, the MG-1 MkII utilises double precision bearings fitted to its dedicated Acetal motor platform and motor bearing support. The motor is aligned using three spike pointed screws making the perfect residual vibration coupling of the motor to the platform itself. This unique design keeps the motor continuously synchronous to provide a drive with constant belt tension.

Simply put, it drives the platter at constant speed without variation. As a finishing touch is the switchable internal mood lighting.

MG-1 MkII platter is a one piece aluminium alloy design based on the SG-1 platter. Only utilising the same precision machining techniques to our extremely high tolerances ensures the smoothest running of the platter and the required inertia that keeps speed constant. Platter/Record interface is a 3mm bonded cast Acrylic disc as used on the SG-1.

It is absolutely critical that the record player motor is powered and controlled faultlessly to ensure a full and musical performance of the record player.

The SG-1 MkIII Motor Drive has new enhanced circuitry for speed accuracy, power delivery. The MkIII utilises two fully protected output power devices with much improved control of the motor. The new output circuit provides the platter with constant and smoother drive.

Added for ease of use are three motor noise-eliminating pots, now accessible from the underside of the unit. Elegant and simple to use with a 'super charged' engine under its bonnet!

### Redline Cable Package

The MG-1 MkII record player comes packaged with the new Redline tonearm cable and motor link cable for the SG-1 Super Groove Motor Drive MKIII.

The Vertere Redline cable system is derived from Pulse-R interconnect cable and follows the same design principles preserving the essence of the analogue audio signal.



The MG-1 MkII has many critical aspects of its design based on the Vertere SG-1 High Performance Record Player. This has enabled the MG-1 to provide vinyl replay beyond what is possible from its class to realise the potential of any high quality audio system.

The precision main bearing, platter assembly, motor and drive system ensure smoothest running, extremely high dynamic range with 'dark' background that is only bettered by RG-1 or SG-1 record players.

The MG-1 MkII with matching SG-1 tonearm is a delight to use. The stylish and beautifully crafted Clear cast acrylic provides consistent performance in different climatic conditions - the MG-1 is also available in specially 'printed' metallic Black or pearlescent White.

The design and attention to the finest details, make this record player a must for lovers of music on vinyl to cherish.



## Specifications

Type	Belt Drive
Motor	24 Pole Synchronous Spindle Support Acetal Ball Bearing
Motor Mount	Acetal Mount - Articulated Double Ball Race Bearing & Silicone Motor Retainer
Pulley	Super Precision Aluminium Alloy
Drive Belt	Precision Ground Polymer
Platter MG-1	Super Precision Aluminium Alloy Single Piece 3mm Bonded Acrylic Record Interface
Bearing Spindle MG-1	Precision Hardened Stainless Steel Roundness/Concentricity & Finish < 2 Microns
Bearing Housing MG-1	High Copper Content Phosphor Bronze Clearance < 7.0 Microns
Plinth Structure	Clear or Special Printed Black Cast Acrylic 20mm Thick Sub, Top & Bottom Plinths
Isolation System	2 Stage Compliant & 1 Stage Rigid 9 Decoupler Sets & Al. Alloy Feet/Foam/SS Ball
Motor Drive P/S	Precision Crystal Referenced
Speeds	33.3 & 45 rpm (<0.3%)
Wow & Flutter	< 0.10%
Rumble	< -80dB
Dimensions	468 x 384 x 140-155mm W x D x H (mm)
Weight	14 Kg

# THE RECORD PLAYER

SG-1 MkII | Super Groove Tri Point Articulated Tonearm

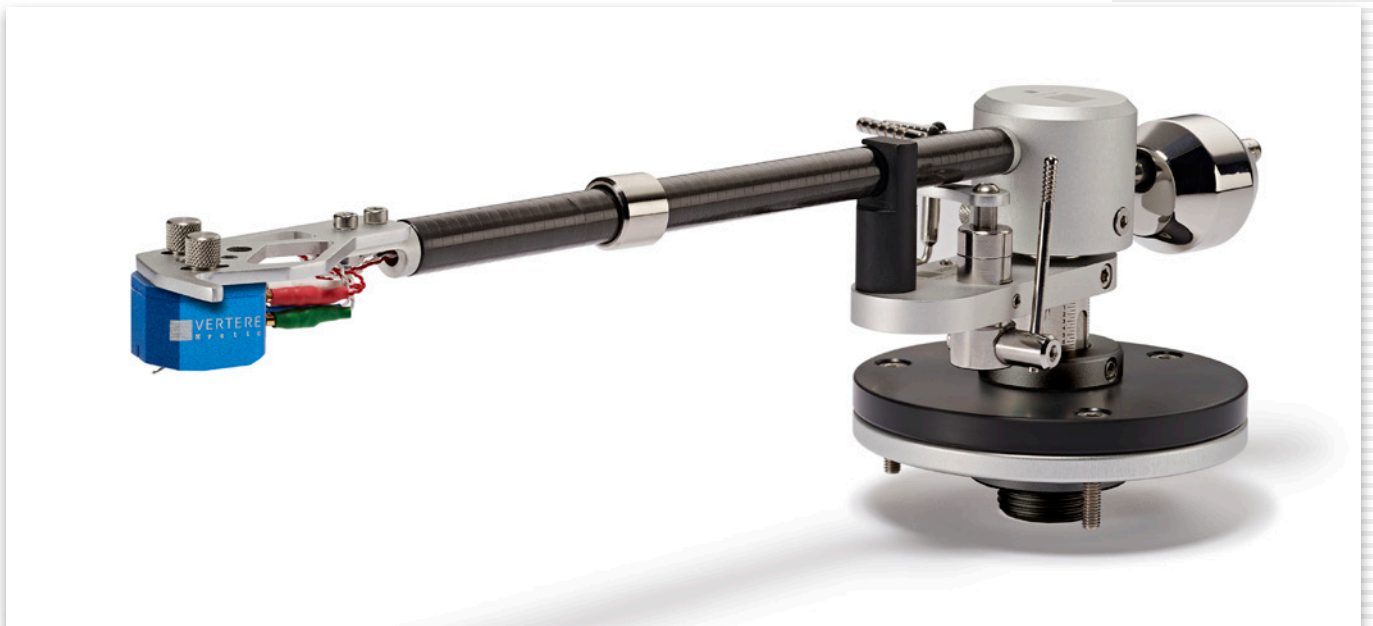



## Vertere SG-1 TPA Tonearm MkII

Vertere Reference Tonearm is a milestone in vinyl replay. Its design, build quality and attention to detail have provided us with performance that is second to none. Of course such quality comes at a price.

It was only natural then to ask if by applying a parallel, albeit different, approach to design we could develop a much more affordable tonearm that was similarly capable of breath-taking performance. This was the beginning of a journey that led us to the introduction of Vertere SG-1 Tri Point Articulated Tonearm.

At first sight the SG-1 Tonearm comes across as a uni-pivot - it is in fact anything but! A true uni-pivot will 'skate' about at its bearing point of contact as the tonearm moves side to side and up and down. This is because there is no such a thing as a 'point'. The bearing point, actually, is a small surface area.

Because of this there is always a certain amount of 'skating' of the bearing point as the arm moves. The magnitude of the skating is in fractions of microns and so is the size of the information stored in the vinyl groove.

To eliminate 'loss' of information due to unwanted bearing chatter, we have designed a Tri Point Articulated bearing - TPA. Three silicone nitride precision balls and a precision machined pivot point provide the support and the articulation for the arm.

Although the SG-1 tonearm may appear to behave as a uni-pivot, it is without any bearing 'chatter' preserving as much of the signal information as possible. The result is a life like dynamic response with unexpected clarity, musicality and detail - truly unparalleled.

The remarkable bearing design is in turn complimented by equally comparable and capable components that make up the SG-1 tonearm.

- \* Roll wrapped carbon fibre arm tube
- \* Aluminium alloy head-shell and bearing yoke
- \* Stainless steel main pillar
- \* Bias curve adjustable anti-skate mechanism
- \* Decoupled stainless steel main counter weight
- \* Triple gold plated proprietary cartridge tags
- \* Triple gold plated proprietary 5-way connector with PTFE insulation
- \* Proprietary internal wiring - Standard Pulse or Pulse Hand-built
- \* Acetal pillar mount with tri-point fixing nut
- \* Arm/Cartridge resonance and fine tracking weight adjustment
- \* New Special Transit Locking Screw
- \* New Setup Assist Counter Weight Locator
- \* New Routing Of Internal Wiring

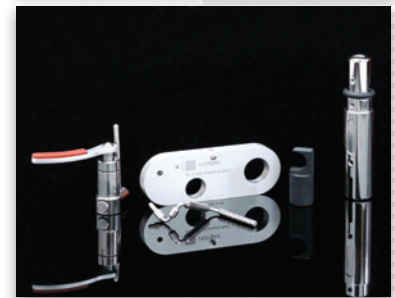

## Specifications

Type	Tri Point Articulated
Effective Length	240mm
Overhang	17.5mm
Offset Angle	22.9°
Head-shell	Aluminium Alloy
Arm Tube	Roll Wrapped Carbon Fibre
Bearing Structure	Captive Silicon Nitride Ball (x3) Precision Machined Stainless Point
Counterweight	Stainless Steel Silicone O-ring Decoupled
Counterweight Locator	Acetal & PETG Locating & Locking Stainless Screws
Fine Tracking Weight Adj. Ring	Stainless Steel Also used to increase/decrease Effective Mass Foam Decoupled
Internal Wiring	Optional Standard Pulse or Pulse Hand-built
Connectors	Proprietary Cartridge Tags & 5-Pin x3 Thickness Gold Plated Contacts
Tonearm Cable	Optional Pulse-HB, Pulse-R, Redline & D-Fi
Weight (With Standard C/W)	397g



# THE RECORD PLAYER

M y s t i c | Moving Coil Phono Cartridge



Vertere Mystic Moving Coil Phono Cartridge is designed and manufactured to exacting standards to provide an uncompromising musical experience.

The body is machined from solid Aluminium alloy and mass tuned to the generator for optimum support and control of unwanted mechanical vibrations. Mounting is via two threaded fixing holes using the supplied stainless steel thumb screws that are also designed for correct coupling of the cartridge body to the tonearm head-shell.

Machined on top of the Mystic cartridge are three specifically designed contact points that provide the exact mechanical coupling area required by the Mystic cartridge. In addition there is a ridge on the top front of the Mystic that assists with the alignment when mounting onto any complementing Vertere tonearm.

Mystic's generator utilises a Samarium-Cobalt magnet and comprises a Cross coil design made of pure copper wires. A two-piece telescopic aluminium tube cantilever supports the Micro Elliptical bonded diamond stylus tip that is designed for maximum tracking ability without compromising on high frequency response or increased surface noise.

This provides a wide band frequency response of below 10Hz to over 40kHz that coupled with an output of 0.5mV will produce a lifelike dynamic range with incredible detail, low frequency punch, depth and precision.

## Specifications

Type	_____	Moving Coil Phono Cartridge
Mounting	_____	Special Tri-Point Contact With M2.5 Threaded Fixing Holes
Magnet type	_____	Samarium-Cobalt
Output Level	_____	0.5mV (1kHz @ 5 cm/s)
Frequency Response	_____	10 Hz - 40 kHz (-3dB)
Coil Impedance	_____	40Ω (per Channel)
Recommended Load	_____	680Ω - 1k5Ω 220pF - 470pF
Channel balance	_____	Better than 1.0 dB
Recommended tracking weight	_____	2.0g (1.9g - 2.1g)
Cantilever	_____	Aluminium Alloy Tube Two-piece Telescopic
Stylus	_____	Micro Elliptical Diamond
Weight	_____	9.1g



# THE RECORD PLAYER

M a g n e t o | Moving Magnet Phono Cartridge



M a g n e t o

Vertere Magneto Moving Magnet Phono Cartridge is designed & manufactured to exacting standards to provide you with years of musical enjoyment.

The Dual Magnet design replicates the structure of the cutter head. The two magnets are arranged in a 'V' form that mimics the Left & Right channel sides of the record groove.

This feature, with an added permalloy centre shield plate, provides a higher frequency response and exceptional channel separation - typically better than 40dB.

The Magneto utilises a finely finished Elliptical stylus to ensure outstanding tracking ability and super quiet tracing of the record groove.

Use of laminated Para-toroidal coils in a 'V' shaped geometry provides much higher efficiency in generating the output audio signal.

The Magneto has its logo cleverly positioned and printed on the top front of the cartridge in line with the stylus tip to facilitate easy installation and alignment. Utilising a detachable stylus assembly also eliminates the need to realign the cartridge and to reset the tracking weight whenever the stylus is replaced.

An absolutely gem of a cartridge for any starter record playing system.

The Magneto is factory fitted to our own DG-1 'Plug & Play' Dynamic Groove record player package.



## M a g n e t o

### Specifications

Type	_____	Moving Magnet
Output	_____	4.5mV (@ 1kHz, 5cm/sec.)
Frequency Response	_____	20Hz - 23kHz
Coil Resistance (per Channel)	_____	800Ω
Recommended Tracking Weight	_____	2.0g
Recommended Load	_____	47,000 Ω 100pF - 220pF
Cantilever	_____	Aluminium
Stylus	_____	Bonded Diamond
Diamond Profile	_____	Elliptical
Weight	_____	6.58g

# THE RECORD PLAYER

## Tonearm Cables | Motor Drive Links

Vertere Reference Tonearm is only partnered with the best tonearm cable, Pulse-HB.

SG-1 Tonearm however can be utilised with Vertere D-Fi, Redline, Pulse-R or even the Pulse-HB tonearm cable.

The weakest link in any system still remains to be the connecting cable and each time the tonearm cable used is improved so will the overall performance and enjoyment of the music played.

### Pulse-HB

An Absolute Reference tonearm cable to provide the best connection between the tonearm and phono amplifier. Pulse-HB will realise the full potential of the record playing system.

HB proprietary Reference Connectors are used throughout utilising special **copper alloy** contacts, precision machined and **23.95 ct** hard gold plated to over **5 microns**.

### Pulse-R

This Reference tonearm cable is derived from the Pulse-HB and utilises conductor configuration that is the closest to the HB. With its secondary shield the Pulse-R provides optimum audio performance and noise rejection. Reference RCA, XLR & 5-Pin DIN connectors used are made from special **copper alloy**, precision machined and **23.95 ct** hard gold plated to over **5 microns**.

### Redline

High performance Redline tonearm cable ensures optimum performance and noise rejection. Bespoke Vertere RCA, XLR & 5-Pin DIN connectors used are specially gold plated to 3 times standard gold plating thickness.

### D-Fi

Utilising two of Pulse-R internal conductors, D-Fi provides a connection to the phono amplifier in line with Vertere principles. This ensures higher performance from any tonearm with real dynamic range, clarity, detail and musicality. D-Fi connectors are all bespoke designed and are specially gold plated to 3 times standard gold plating thickness.



VERTERE™

### Motor Drive Link Cables

The Motor Drive is effectively an amplifier that controls the record player motor. The better the drive control and the AC signal is to the motor, the smoother will be the running of the platter. This will ensure quieter back ground, higher dynamics and even more accurate timing. As the Motor Drive Link cable is improved so does the overall performance and enjoyment of the music played on the record player - the results speak for themselves!

### Pulse-HB

An Absolute Reference Motor Link cable for best possible record player performance. This is a must in any serious RG-1, SG-1 & MG-1 record playing system.

### Pulse-R

A Reference Motor Link cable second only to the Pulse-HB. With a secondary shield the Pulse-R provides perfect balance between highest performance and noise rejection.

### Redline

This is a high performance Motor Link utilising Pulse-B cable to ensure optimum performance and noise rejection.







VERTERE™

### RECORD PLAYING SYSTEMS

RG-1 Reference Groove Record Player  
SG-1 Super Groove Record Player  
MG-1 Magic Groove Record Player  
DG-1 Dynamic Groove Record Player

### MOTOR DRIVES

RG-1 Reference Motor Drive  
SG-1 MkIII Super Groove Motor Drive

### TONEARMS

Vertere Reference Tonearm **New Gen.**  
SG-1 MkII Tonearm PULSE-HB Internal Wiring  
SG-1 MkII Tonearm Standard PULSE Internal Wiring

### PHONO CARTRIDGES

**Mystic** Moving Coil Cartridge  
**Magneto** Moving Magnet Cartridge

### PHONO PREAMPLIFIER

PHONO-1 MkII

### ANALOGUE INTERCONNECT CABLES

PULSE-HB  
PULSE-R  
PULSE-**Redline**  
D-Fi  
RCA, XLR Balanced, DIN & 5-Pin Tonearm

### SPEAKER CABLES

PULSE-HB  
PULSE-XS Reference  
PULSE-XS  
PULSE-XminiS  
D-Fi  
7mm, 4mm Banana & Spade - Single Ended Or Bridged Balanced

### DIGITAL INTERCONNECT CABLES

PULSE-HB  
PULSE-R  
D-Fi  
USB TypeA, TypeB, Mini, Micro, Ethernet RJ45  
COAX-75 Ohm RCA & BNC, AES/EBU Balanced XLR

### MAINS POWER CABLES & DISTRIBUTION

PULSE-HB & HB MAINS DISTRIBUTION BLOCK  
PULSE-**Redline**  
UK, EU, US: IEC & IEC 20A

### RECORD PLAYER SUPPORT

STAGE-1 REFERENCE ISOLATION PLATFORM

### EQUIPMENT SUPPORT

STAND-1 REFERENCE EQUIPMENT SUPPORT

